

Origami Three-Headed Dragon

[First draft – may contain errors]

Donya Quick

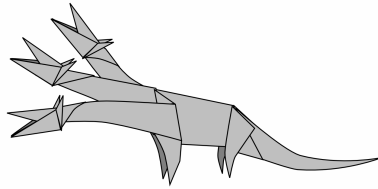

Difficulty: [undecided]

Recommended paper: thin or foil, at least 15cm (6 in.).

This design is for a three-headed dragon without wings. Each head has a mouth and two ears or horns.

Begin with the paper colored side up.

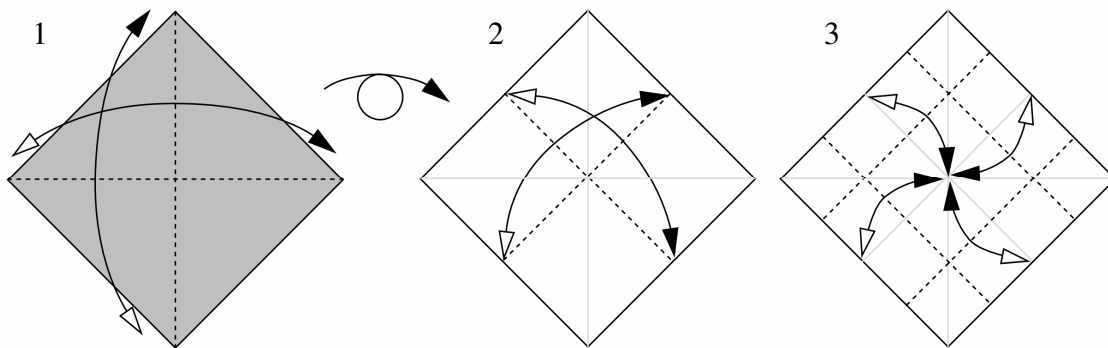

Step 1 – 3: fold and unfold on both diagonals and both edge-parallel axes. Fold and unfold again to divide the paper into 16 equally sized squares.

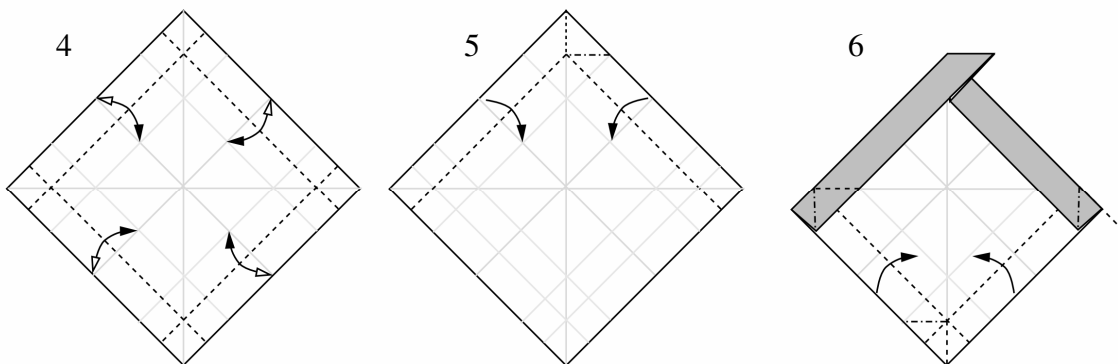

Step 4 – 6: fold and unfold to the creases made in step 3, then rabbit ear fold. Perform folds on the other 3 corners to duplicate the fold from step 5.

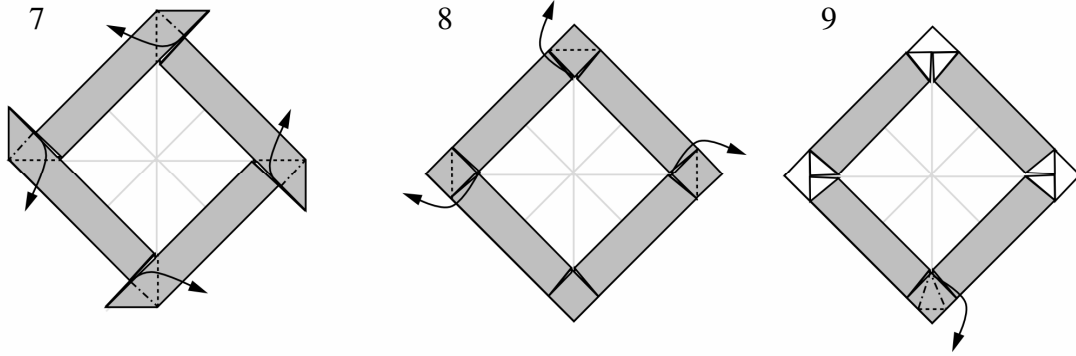

Step 7 – 9: squash fold all four sides. Fold up the triangular flaps on three of the sides. These will become the heads. Petal fold the bottom flap down, forming the tip of the tail.

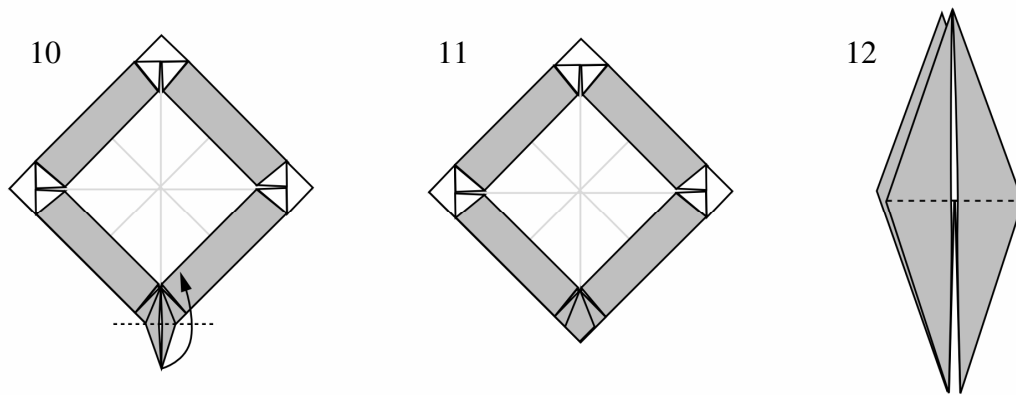

Step 10 – 11: fold the tip of the tail up. Treat this side of the paper as the white side, and fold the bird base. Each of the tips of the large flaps in the bird base will now contain some extra paper. Make sure the flap containing the tip of the tail is at the *back* of the model. Pull the inside paper out.

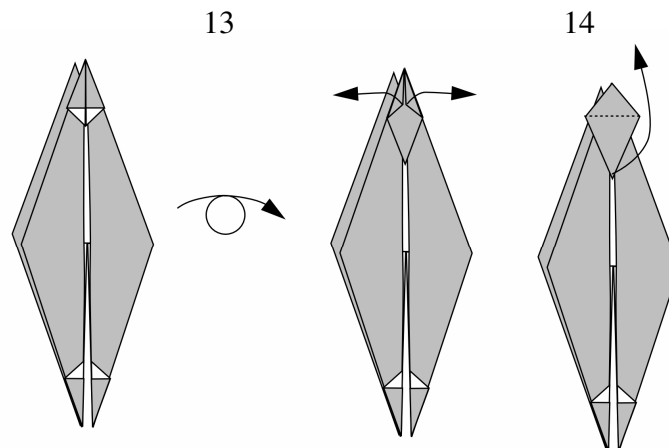

Step 13 – 14: turn the model over, and unfold the small flaps on the tail. Fold the tip up as far as it will go.

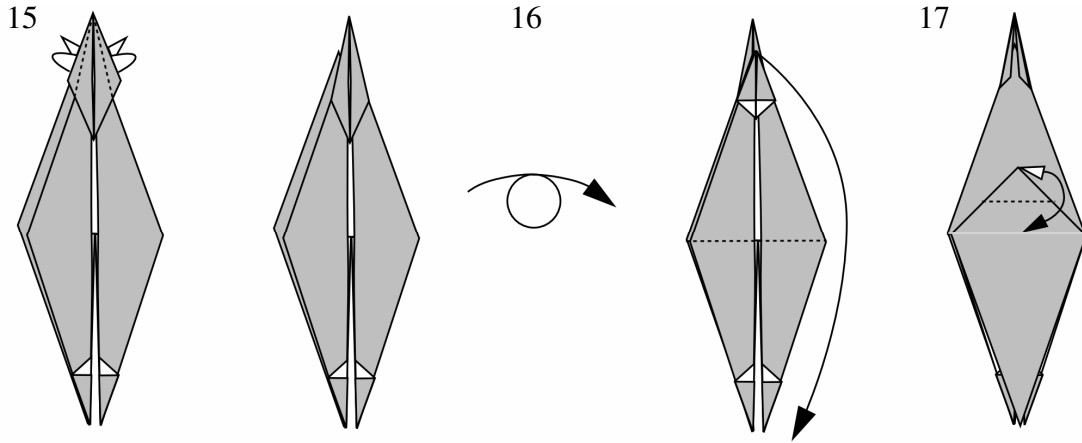

Step 15 – 17: fold the sides in to thin the tail. Turn the model over again, then fold the top flap down so that all of the “head” flaps are pointing the same direction. Fold and unfold the tip of the middle flap.

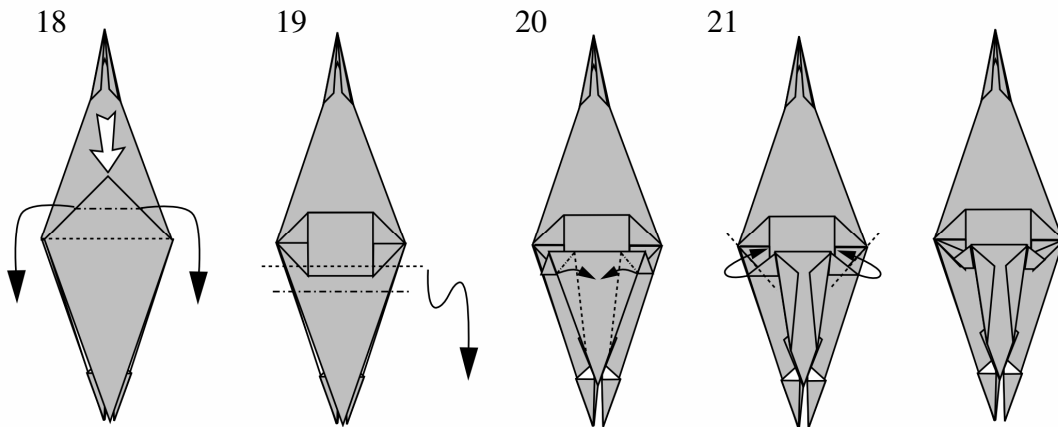

Step 18 – 21: spread squash fold. Zig-zag the lower flap, then squash fold the edges in. Inside reverse fold on both sides.

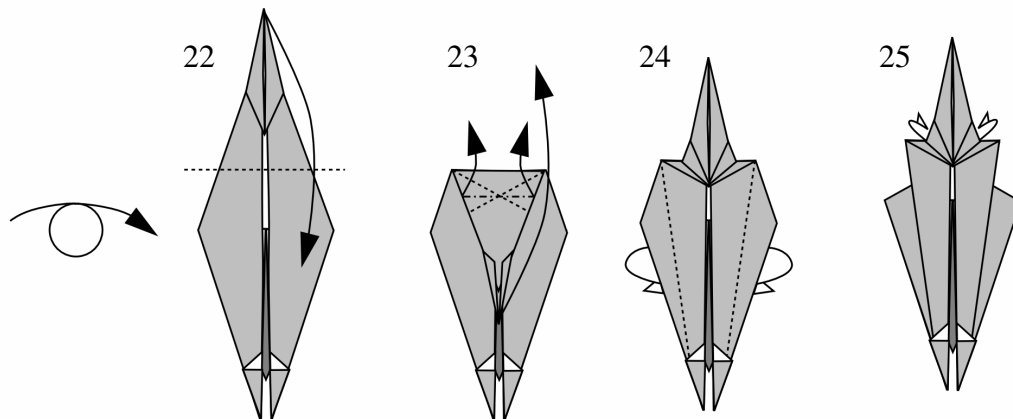

Step 22 – 25: turn the model over. Fold the top flap down, then collapse the paper along the lines shown (similar to the waterbomb base). Fold the far edges in. It is important that these edges go in between the other layers, not over them. Reverse the folds for the tail so that the base of the tail lies underneath the paper that will form the hind legs.

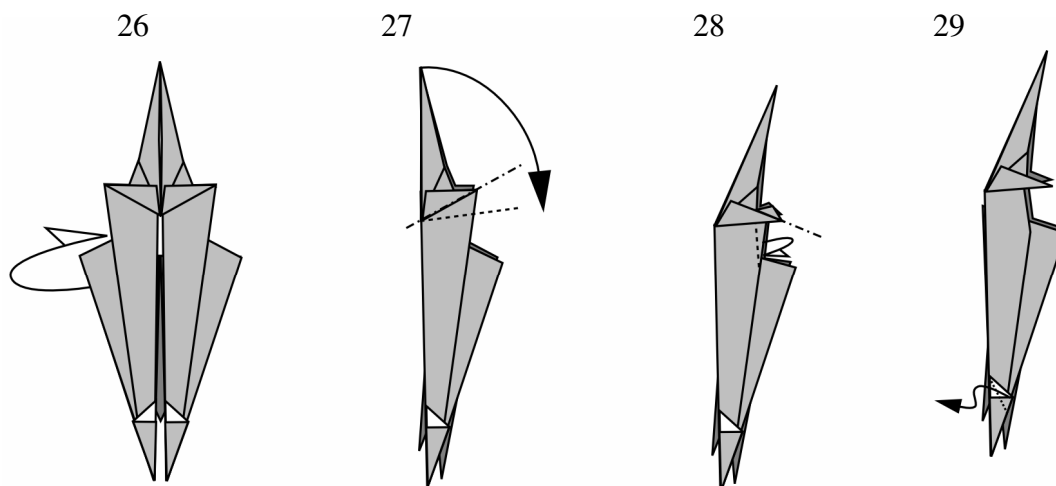

Step 26 – 29: fold the model in half, then outside crimp fold the hind legs and tail. Fold the edge in to thin the legs and body. Inside reverse fold the side of the nearest head. Repeat this fold on the other side of the same head.

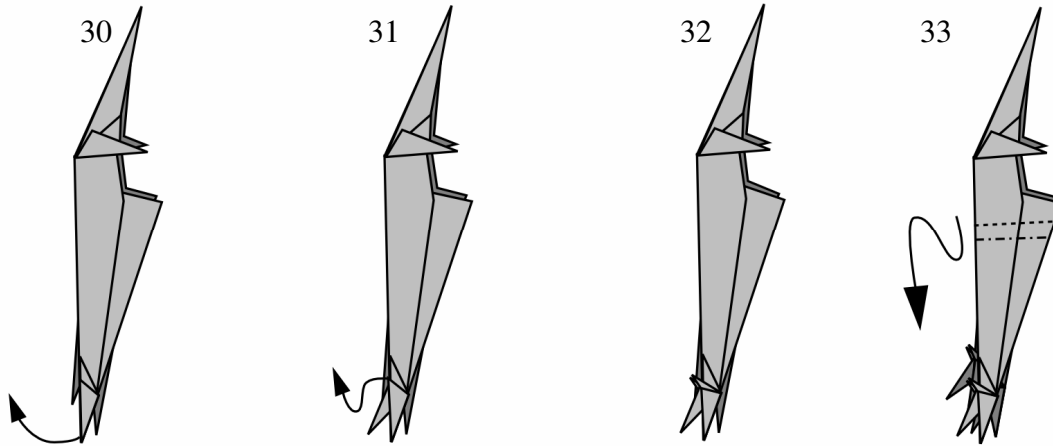

Step 30 – 31: reach inside the top of the head to pull out the hidden flap of paper. On foil paper, this step may require unfolding the heads mostly to avoid paper crinkles. Allow the paper to flatten again with the flap up and the small side flaps unaltered. This will form the upper jaw. Zig-zag the flaps on the side slightly to form ears or small horns.

Step 32 – 33: repeat steps 29 – 31 on the other two heads. After that, Zig-zag the neck of the nearest head.

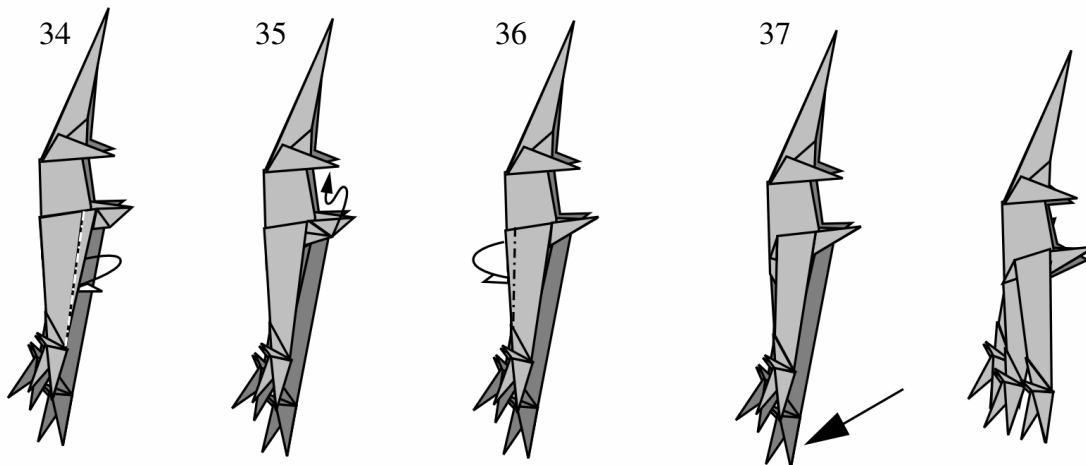

Step 33 – 37: inside reverse fold to narrow the neck and front leg, then inside reverse fold to narrow the leg again. Inside reverse fold the top of the neck to narrow it some more. Repeat this on the other side (the farthest head). Shape the model as desired.

